

ISOLATED DIRECT DRIVE PLENUM FAN (IDDP)

PART# 0601710001_rev_A

INSTALLATION, OPERATION & MAINTENANCE MANUAL

Please read and save these instructions for future reference. Read carefully before attempting to assemble, install, operate or maintain this product. Protect yourself and others by observing all safety information. Failure to comply with instructions could result in personal injury and/or property damage!



TABLE OF CONTENTS

Introduction	1
General Safety Information.....	2
Shipping, Receiving & Handling	3
Storage	4
Short Term	
Long Term	
Storage Procedures	
Bases	
Unit Start-Up	5
Maintenance	6
Motor	
Structural	
Troubleshooting Guidelines	7
Installation.....	8
Radial Gap, Overlap, Impeller Alignment	9
Fan Spacing	10
Piezometer Ring Data	11

INTRODUCTION

This Installation Manual is provided as a guide for the installation of fans manufactured by Lau. It is the responsibility of the purchaser to provide qualified personnel experienced in the installation, operation, and maintenance of air moving equipment. Instructions given in this manual are general in nature and apply to a variety of models manufactured by Lau. Read this Installation Manual completely before installing the fan. Additional product and engineering information is available at www.Laufan.com. Always follow good safety practices when installing, maintaining and operating air moving equipment.

GENERAL SAFETY INFORMATION

Only qualified personnel should install the fan. Personnel should have a clear understanding of these instructions and should be aware of general safety precautions. Improper installation can result in electric shock, possible injury due to coming in contact with moving parts, as well as other potential hazards.

Some important Guidelines:

- Follow all local electrical and safety codes, as well as the National Electrical Code (NEC) and the National Fire Protection Agency (NFPA), where applicable. In Canada, follow the Canadian Electric Code (CEC).
- The rotation of the impeller is critical. It must be free to rotate without striking or rubbing any stationary objects.
- Motor must be securely mounted and adequately grounded.
- Do not operate fan impeller faster than max catalogued fan rpm. Adjustments to fan speed significantly effects motor load. If the fan speed is changed, the motor current should be checked to be sure it is not exceeding the motor nameplate amps.
- Do not allow the power cable to kink or come in contact with oil, grease, hot surfaces, or chemicals. Replace power cable immediately if damaged.
- Verify that the power source is compatible with the equipment.



When servicing the fan, the motor may be hot enough to cause pain or injury. Allow motor to cool before servicing



Always disconnect power before working on or near a fan. Lock and tag the disconnect switch



Precaution should be taken in explosive atmospheres

SHIPPING & RECEIVING

All Lau products are carefully constructed and inspected before shipment to insure the highest standards of quality and performance. Compare all components with the bill of lading or packing list to verify that the proper unit was received. Check each unit for any damage that may have occurred in transit. Any damage should be reported immediately to the carrier and the necessary damage report filed.

HANDLING

Handling of all air moving equipment should be conducted by trained personnel and be consistent with safe handling practices. Verify the lift capacity and operating condition of handling equipment. Maintain handling equipment to avoid serious personal injury. Units shipped completely assembled may be lifted with slings and spreader bars. Lift the fan in a fashion that protects the fan and fan coating from damage. Never lift a fan by the inlet or discharge flange, shafting or drives, impeller, motor, motor base, or in any other manner that may bend or distort parts.

Lifting Instructions

Fans are designed to be lifted and moved as a single module. See below for designed lifting points for the fan.

- Carefully remove any crate and packing materials.
- Place the fan(s) onto the mounting structure using the recommended lifting points as shown. Lift each fan individually into position.

Preferred lifting method

A Clevis Hook



Alternate lifting method

B S-Hook

↑ Lifting Points
– 5/8" diameter holes

Maximum Fan Weight Specifications

Fan Size	Max. Total Fan Weight (lbs.)
105	240
122	250
135	275
150	308
165	327
182	412
200	435
222	486
245	519
270	685
300	1029
330	1303
365	1323
402	1407

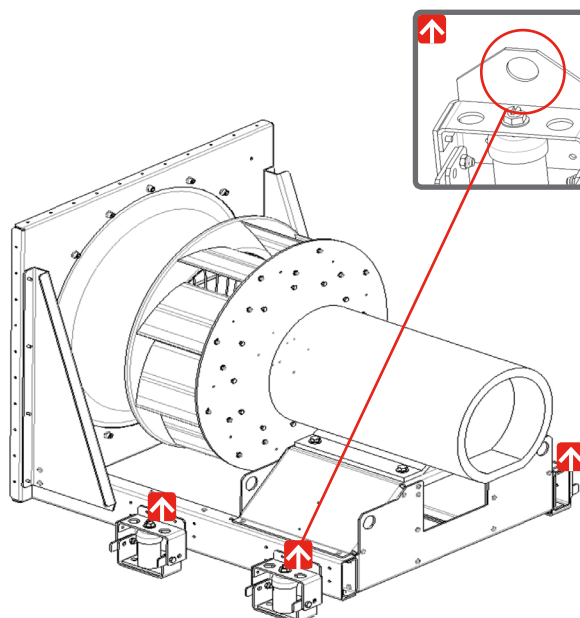

SHORT TERM STORAGE

If fan installation is delayed, store the unit in a protected area. Protect the fan and motor bearings from moisture and vibration (or shock loading).

LONG TERM STORAGE

If a fan is to be stored for any length of time and the bearings are re-greasable, the motor bearings should immediately be filled with grease while rotating the fan and then the bearings should be re-greased and rotated monthly. This will prevent moisture, which condenses within the bearing, from corroding the raceways.

STORAGE PROCEDURES

Fans should be stored indoors whenever possible where control over temperature, humidity, shock and dust is reasonably maintained. If units are to be stored outside, they should be covered with a water-resistant material. Stored equipment should be on a clean, dry floor or blocked up off the ground to prevent unit from setting directly on the ground.

Periodic Check

On a monthly interval, the equipment should be checked to ensure that it has remained in an acceptable stored condition. The fan and motor should be rotated several times by hand. The fan impeller should be left at approximately 180 degrees from that of the previous month to prevent damaging the motor bearings.

BASES (Foundation and Isolation)

Critical to every fan installation is a strong, level foundation. Structural bases must be sturdy enough to prevent flexing and vibration. Lau recommends using a spring isolated inertia base for all Stack Fan applications. Design, fabrication, and installation of the isolation base are the customers responsibly.

After the fan, isolation base, and isolators are installed, the entire assembly must be leveled. Floor mounted fans should be installed on a flat, level, rigid foundation.

Fans mounted to or within a structure should be placed as close as possible to a rigid member such as a wall or column. The structure must be designed for rotating equipment; static design for strength is not sufficient to insure proper operation. Structural resonance should be at least 20% above the maximum fan operating speed.

Any ducting should have independent support; do not use the fan to support ducting. Isolating the fan from ductwork with flex connections eliminates transmission of vibration.

UNIT START UP

When the unit is removed from storage, all grease should be purged and replenished with fresh grease. The following check list should be adhered to insure proper operation:

Operation Check List

Verify that proper safety precautions have been followed:

- Electrical power must be locked off.

Check fan mechanism components:

- System connections are properly made and tightened.
- Impeller and fan surfaces are clean and free of debris.
- Rotate the impeller by hand to verify it has not shifted in transit.

Check fan electrical components:

- Motor is wired for proper supply voltage.
- Motor was properly sized for power
- Motor is properly grounded.
- All leads are properly insulated.

Trial “bump”:

- Turn on power just long enough to start assembly rotating.
- Check rotation for agreement with rotation arrow.

Perform checklist again until unit is operating properly. Verify fastener tightness. These may have loosened during shipment or installation.

- Bushing set screw torque
- Bolts on inlet funnel.
- Motor bolt torque
- Nuts holding housing frame to base and base to ground (customer specifications)
- Bushing fastener torque
- Ensure piezo ring tubing will not contact the impeller

C Bushing Fastener Torque

Bushing Type	Screw Size	Recommended Torque
JA	10-24	60 in-lbs.
SD/SDS	¼-20	108 in-lbs.
SK	5/16-18	180 in-lbs.
SF	3/8-16	360 in-lbs.

D Bushing Set Screw Torque

Bushing Type	Screw Size	Recommended Torque
SD/SDS	¼-20	60 in-lbs.
SK	5/16-18	110 in-lbs.
SF	3/8-16	200 in-lbs.

Motor Bolt Torque

NEMA Frame	Bolt Size (Grade 5)	Washers Size (Top and Bottom)	Recommended Torque(ft-lb)
56-145T	5/16	5/16	18
182-215T	3/8	3/8	31
254U-286TS	1/2	1/2	75
324T-365T	9/16	9/16	107

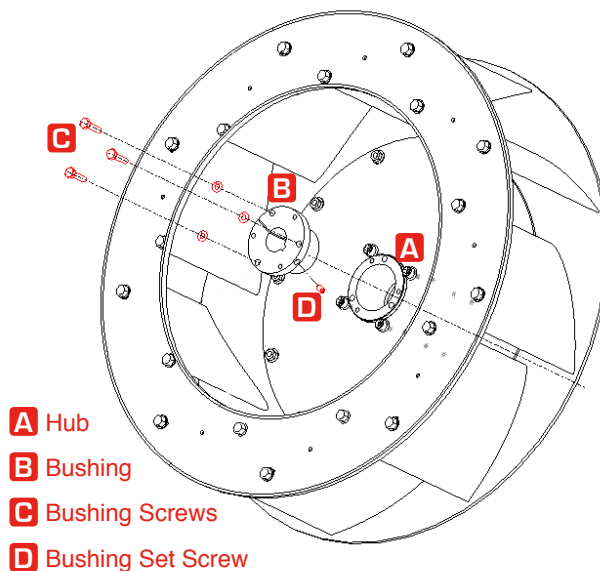

MOTOR MAINTENANCE

The three basic rules of motor maintenance are: keep the motor clean, dry and properly lubricated. Keeping motors and windings clean is important because dirt and dust can cause heat to be trapped causing overheating and/or premature failure. Blow dust and dirt out of windings and off the motor periodically. Use low pressure (50 psi) airstream to prevent winding damage. Keep the areas surrounding the motor clear so the air can circulate through the motor cooling fan.

Motors should be kept dry to avoid electrical short circuits. Motors kept in storage for long periods of time can have moisture condense on the windings. Be certain the motor is dry before using.

Some smaller motors are permanently lubricated. Motor bearing lubrication, if required, must follow a rigorous schedule. Motors less than 10 hp running eight hours a day in a clean environment should be lubricated once every five years; motors 15 to 50 hp, every 3 years; and motors 50 to 150 hp, yearly. See motor manufacturer specifications for recommended greases. For motors in a dusty or dirty environment or running 24 hours a day, divide the service interval by 2. If the environment is very dirty or high temperatures exist, divide the service interval by 4. Lubrication requirements are normally attached to the motor. Do not over-lubricate.

The major cause of motor bearing failure is contamination of grease, insufficient grease, over lubrication, and incompatibility of grease. If a fan is to be stored for any length of time and the bearings are re-greasable, the motor bearings should immediately be filled with grease while rotating the fan and then the bearings should be re-greased and rotated monthly. This will prevent moisture, which condenses within the bearing, from corroding the raceways.

STRUCTURAL MAINTENANCE

All structural components or devices used to support or attach the fan to the isolation base, or other structure should be checked at regular intervals. Vibration isolators, bolts, foundations, etc, are subject to failure from corrosion, erosion, and other causes. Improper mounting can lead to poor operation characteristics, fan fatigue, and failure. Check components for corrosion, cracks, or other signs of stress.

TROUBLESHOOTING GUIDELINES

Use safety practices when investigating fan or system performance problems.

General safe practices and performance troubleshooting guidelines can be found in AMCA Publication 410: Recommended Safety Practices for Users and Installers of Industrial and Commercial Fans, and AMCA Publication 202-98 (R2011): Troubleshooting. Fan application and field measurement procedures can be found in AMCA Publication 201-02 (R2011): Fans and Systems and AMCA Publication 203-90 (R2011): Field Performance Measurement of Fan Systems.

Troubleshooting Performance Problems:

The lists below indicate possible areas to check when air or sound values do not meet expectations. Most fan problems can be pinpointed to one of these common causes.

Air Capacity Problems:

- 1. Resistance of system not at design rating.**
If resistance is lower than expected airflow can be higher and horsepower can be lower. If resistance is higher than anticipated, air volume will be down.
- 2. Fan speed is not at design speed.**
- 3. Air density not at design values.** Also check air performance measurement techniques / procedures.
- 4. Mechanical air devices (e.g. dampers), are closed or plugged.** Also check filters.
- 5. Impeller mounted improperly or is rotating in reverse.**
- 6. Parts of system or fan have been damaged or need cleaning.**

Noise Problems:

- 1. Fan is not at design point of operation.**
Fan forced to operate in an unstable flow region.
- 2. Bearing failure.** Check bearings.
- 3. Supply voltage high or inconsistent supply frequency.** Adjustable frequency controllers can generate motor noise.
- 4. Objects which are installed in a high velocity airstream can generate noise.** This includes flow sensors, turning vanes, etc.
- 5. Non-uniform fan inlet conditions.**
- 6. Acoustics or sound measurement procedure incorrect.**

Vibration Problems:

- 1. Misalignment of drive components.**
- 2. Poor foundations (isolation base) or mounting structure (resonances).**
- 3. Foreign object trapped in rotating components.**
- 4. Damaged rotating components (bearings, shaft, fan, impeller).**
- 5. Broken, loose or missing setscrews.**
- 6. Loose bolts.**
- 7. Vibration transmitted by another source.**
- 8. Water accumulating in airfoil blades.**
- 9. Fan is operating in stall or unstable flow region.**

NOTE: All fans manufactured by Lau are factory balanced prior to shipment. Improper handling and movement of the fan during shipment may cause the rotating assembly to shift out of alignment. Balance should be checked once the fan is installed. If a final trim balance is required, it is the end user's responsibility to bring the fan back to factory specifications. Final trim balancing is not the responsibility of Lau.

INSTALLATION

Bolt the fan to the isolation base, or other structure, and adjacent fans using the inlet and outlet mounting flanges. The first row of fans should be securely installed before installing the second row of fans. **Lau does not recommend lifting and moving assembled StackFan modules, as this may cause bending, distortion, and lead to component misalignment.**

Installation Instructions for Restrained Spring Isolators [FIGURE 1]

1. Identify the location of each isolator with the appropriate submittal drawing. (if supplied)
2. Locate the bottom spring holes in position and secure to the base.
3. Remove the bolt and nut from the side of each lower spring bracket and remove the shipping lock. The bolts and nuts are to be discarded.
4. Turn the leveling bolt counter clockwise on the lowest equipment corner until the equipment is level. Do not attempt to place all the weight on one spring, but distribute the load proportionately by adjusting each isolator in sequence.
5. Adjust the isolator by turning the leveling nut counterclockwise one turn. Repeat this step to each isolator leveling nut, one turn at a time, until the housing top plate is centered between the rubber snubbing pads on the leveling screw on all isolators.

Installation Instructions for Neoprene Isolators [FIGURE 2]

1. Identify the location of each isolator with the appropriate submittal drawing. (if supplied)
2. Locate the bottom spring holes in position and secure to the base.
3. Remove the bolt and nut from the side of each lower spring bracket and remove the shipping lock. The bolts and nuts are to be discarded.

NOTE: Do not attempt to move the equipment laterally while it is supported on the isolators. If it is necessary to move the equipment, remove the weight from the isolators by raising the equipment. Failure to follow this procedure could result in bent or broken leveling bolts or springs, or damage to the neoprene bottom spring cap.

[FIGURE 1]

- A** Shipping Lock
- B** Leveling Bolt
- C** Bottom Spring Holes

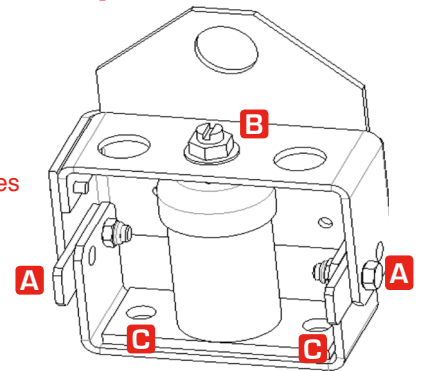

6. Continue to adjust each leveling bolt (in sequence) until the equipment is at its operating height.
7. Tighten the small cap screw, thus securing the spring isolator to the supported equipment and locking the leveling bolt against turning.

NOTE: Do not attempt to move the equipment laterally while it is supported on the isolators. If it is necessary to move the equipment, remove the weight from the isolators by raising the equipment. Failure to follow this procedure could result in bent or broken leveling bolts or springs, or damage to the neoprene bottom spring cap.

[FIGURE 2]

- A** Shipping Lock
- C** Bottom Spring Holes

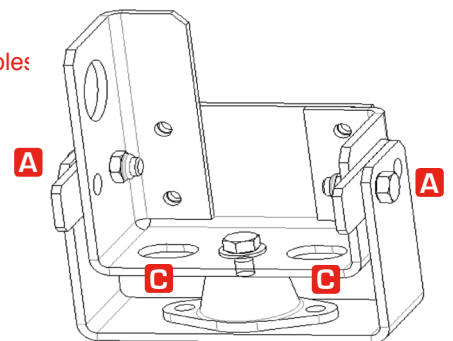

RADIAL GAP, OVERLAP AND IMPELLER ALIGNMENT

Efficient fan performance can be maintained by having the correct gap and overlap between the impeller and inlet funnel. These items should be checked at installation, after the fan has been in operation for 24 hours, and after the unit has been serviced.

Gap– distance between the OD of the funnel and the ID of the impeller concentricity.

Overlap– distance the funnel and impeller overlap one another.

This sketch shows both the gap and overlap dimensions for all sizes.

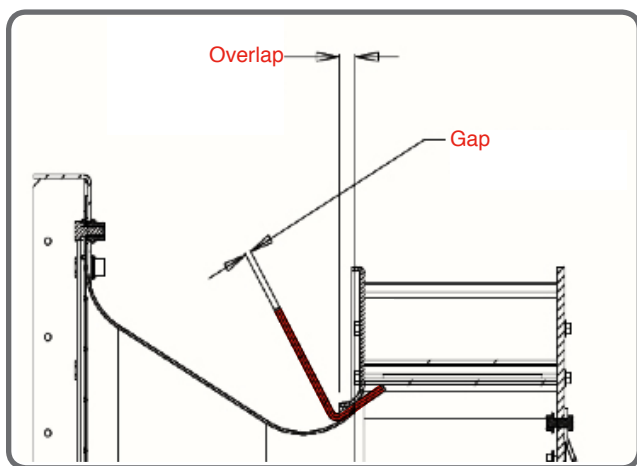

Gap is adjusted by loosening the inlet funnel bolts and centering the funnel on the impeller.

Caution: Never loosen the motor attachment bolts to make adjustments to the impeller-to-funnel gap.

Overlap is adjusted by loosening the impeller hub from the shaft and moving the impeller to the desired position along the shaft. The transition between the inlet funnel and impeller should be as shown; there is a smooth feel to the profile when moving from one component to the other.

Gap / Overlap Dimensions

Model	Minimum Overlap (Inches)	Maximum Overlap (Inches)	Minimum Gap (Inches)
105	0.12	0.29	0.06
122	0.12	0.32	0.07
135	0.12	0.35	0.07
150	0.19	0.41	0.09
165	0.25	0.47	0.11
182	0.31	0.5	0.11
200	0.38	0.57	0.12
222	0.44	0.63	0.14
245	0.5	0.69	0.17
270	0.56	0.76	0.2
300	0.62	0.88	0.24
330	0.75	0.96	0.26
365	0.81	1.13	0.27
402	0.88	1.23	0.31

FAN SPACING

Location and Placement of Plenum Fans in Air Handlers

- Center the fan inlets in both the horizontal and vertical planes.
- **A** Shows guidelines for spacing two or more fans side by side in the plenum. Fans should not be closer than one-half the wheel diameter.
- For inlet clearance, see **B**. A minimum of one fan impeller diameter clearance is recommended.

Fan spacing with two or more fans

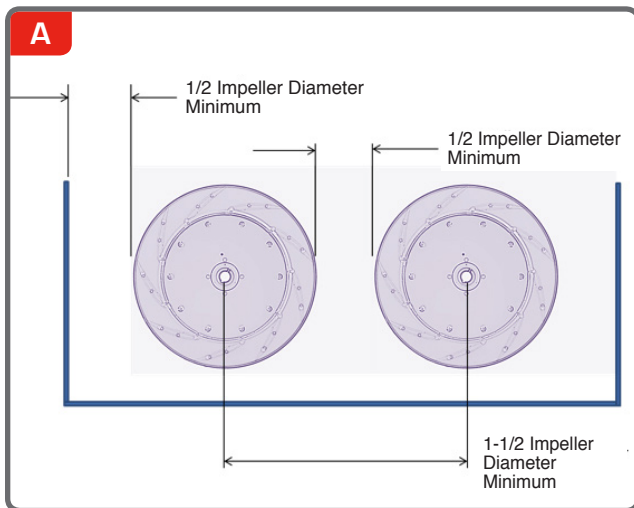

Recommended Inlet Spacing

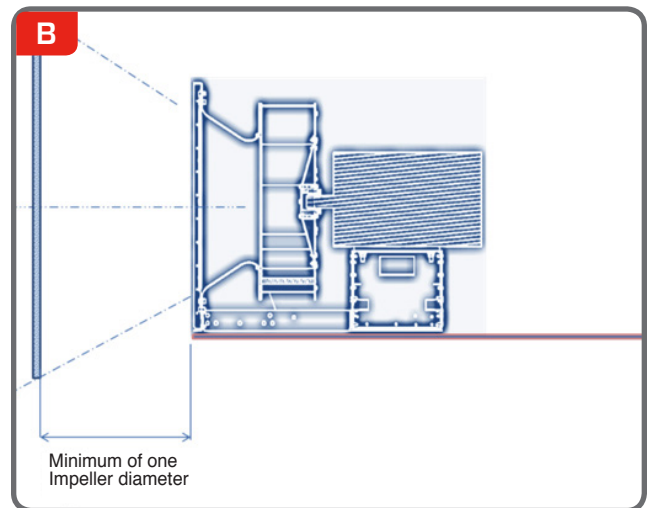

Location and Placement of Plenum Fans in Air Handlers

- Center the fan inlets in both the horizontal and vertical planes.
- **A** shows guidelines for spacing two or more fans side by side in the plenum. Fans should not be closer than one-half the wheel diameter.
- For inlet clearance, see **B**. A minimum of one fan impeller diameter clearance is recommended.

PIEZOMETER DATA

HOW IT WORKS

The Piezo system is based on the principle of a flow nozzle. The inlet funnel of the fan is used as the flow nozzle, and the flow can be calculated by measuring the static pressure drop through the inlet funnel. The pressure drop is measured from the tap located on the face of the inlet funnel to the piezometer in the throat. The inlet tap is connected to the high-pressure side of the transducer and the piezometer is connected to the low-pressure side (see diagram below).

Measurement of Airflow

***Note- please contact Lau if fan has multiple tap locations on funnel.**

Several factors affect the accuracy of this method of determining flow. The equations below assume the following:

- There are no vanes or other obstructions in or near the inlet
- Flow entering the funnel (no pre-swirl)
- Impeller to inlet funnel overlap
- Accurate determination of air density at the inlet

K Factor

Fan Size	iCorus & Corus DDP	Stack Fan
105	592	592
122	842	842
135	963	963
150	1147	1147
165	1450	1450
182	1671	1671
200	2087	2087
222	2458	2458
245	2941	2941
270	3597	
300	4641	
330	5352	
365	6629	
402	7943	

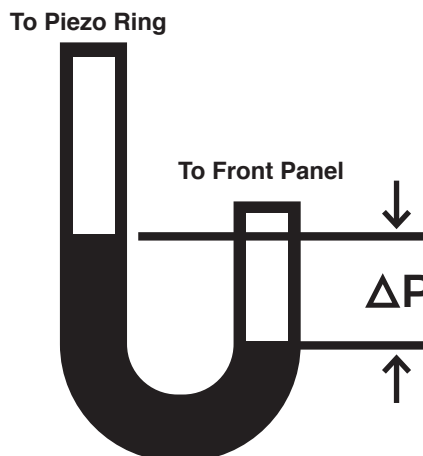
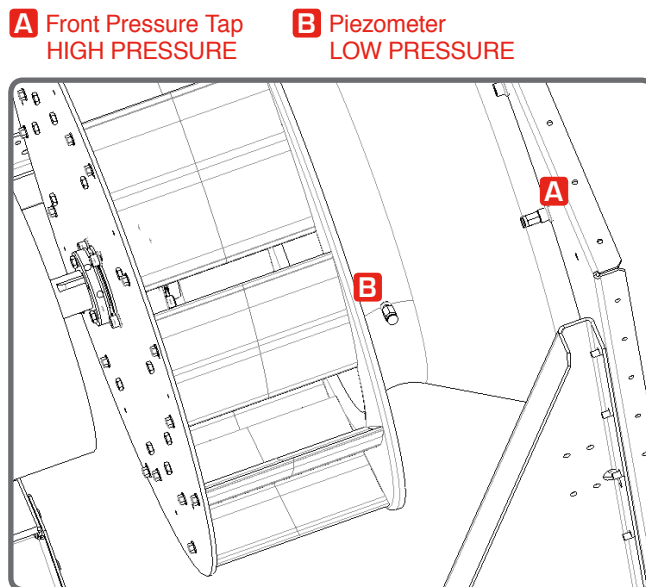

Calculation when using the Piezo Meter

For standard air ($\rho = 0.075 \text{ lb/ft}^3$):

$$(\text{CFM}) = K \text{ Factor} * \sqrt{(\text{delta pressure})}$$

- K Factor = value from chart
- Delta Pressure (ΔP) = The differential in static pressure from the piezometer and the front pressure tap (inches w.g.)



ISOLATED DIRECT DRIVE PLENUM FAN (IDDP)

PART# 0601710001_rev_A



For more information visit LauFan.com. Call 937-476-6500

 Follow Lau @LauOEM



ISO9001
CERTIFIED